

NOTE: INSTALLATION BY LICENCED HOMETECH INSTALLER AS PER THE SOLATUBE AUSTRALIA MANUFACTURING SPECIFICATION

RAYBENDER 3000 TECHNOLOGY  
LIGHT TRACKER REFLECTOR, TO FACE NORTH

NO. 12 TEK SCREWS THROUGH POLYPROPYLENE FLASHING INTO METAL DECK  
PROFILED FLASHING BY SOLATUBE TO SUIT PRESSED METAL ROOFING.

70  
190  
DIFFUSER MOUNTING RING  
EXISTING CEILING

SECTION B-B  
SCALE 1:5

4 NO. DOME SCREWS  
MOHAIR  
12-11 TEK SCREWS THROUGH FLASHING INTO METAL DECK  
DECROMASTIC TILE TURNED UP UNDER FLASHING  
EXISTING PRESSED METAL ROOF  
EXISTING BATTENS  
TOP EDGE OF FLASHING UNDER ROOFING  
150  
BUILDING PAPER TURNED UP AS PER DETAIL D  
SPECTRALIGHT INFINITY - 98.6% SPECTRAL REFLECTIVITY  
DUAL GLAZED DIFFUSER AS SPECIFIED

LIGHTBENDER REFLECTOR, TO FACE NORTH  
SEE COMPRESSIBLE 'C' AIR SEAL  
DETAIL 'C'

SPECTRALIGHT INFINITY - 99.7% SPECTRAL REFLECTIVITY  
NOTE: INSTALLATION BY LICENCED HOMETECH INSTALLER AS PER THE SOLATUBE AUSTRALIA MANUFACTURING SPECIFICATION

PROFILED FLASHING BY SOLATUBE TO SUIT PRESSED METAL ROOF PROFILE

EXISTING PRESSED METAL ROOF

PHONE: 0800 466-383  
WEB: www.hometech.co.nz

SECTION A-A  
SCALE 1:5

EXISTING PRESSED METAL ROOF  
EXISTING RAFTER

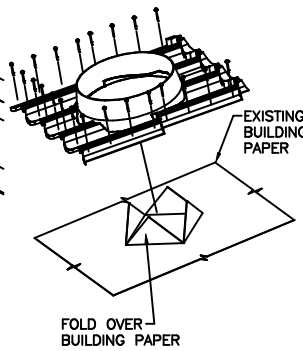

DETAIL D - 3D EXPLODED VIEW  
N.T.S.

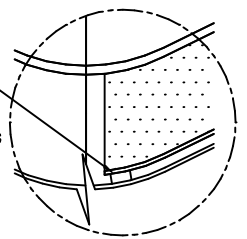

NOTE: INSTALLATION BY LICENCED HOMETECH INSTALLER AS PER THE SOLATUBE AUSTRALIA MANUFACTURING SPECIFICATION

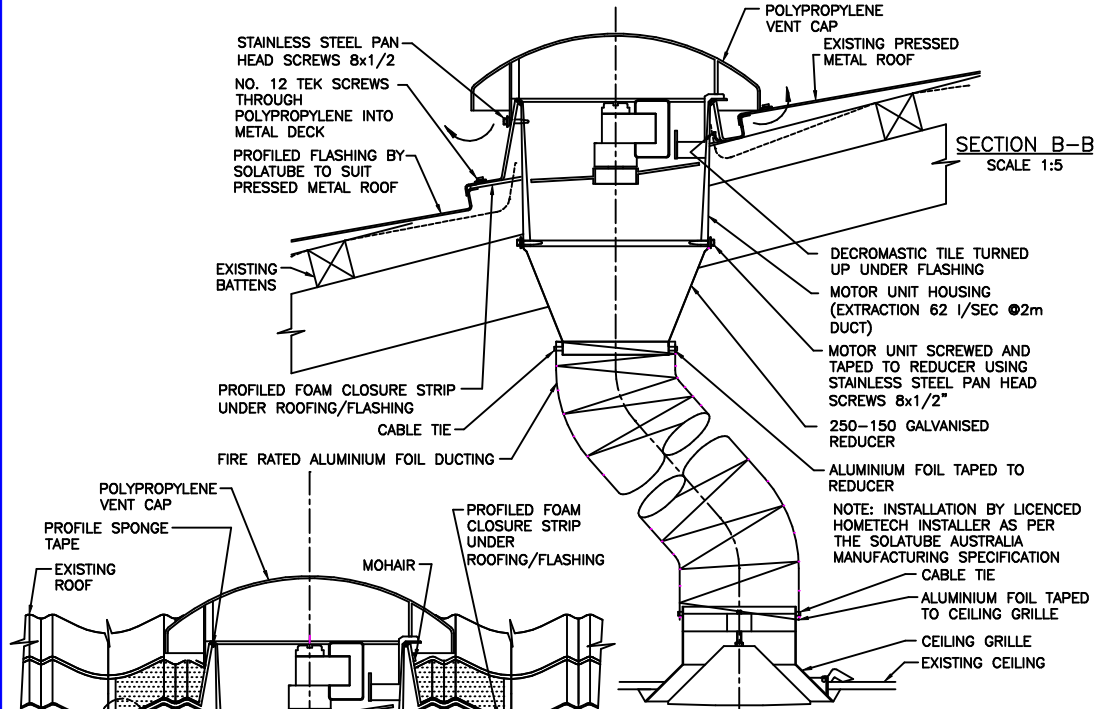

SECTION B-B  
SCALE 1:5

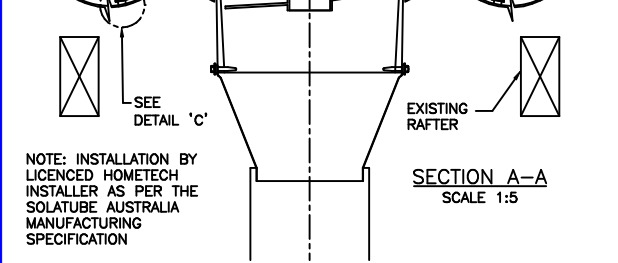

NOTE: INSTALLATION BY LICENCED HOMETECH INSTALLER AS PER THE SOLATUBE AUSTRALIA MANUFACTURING SPECIFICATION

SECTION A-A  
SCALE 1:5

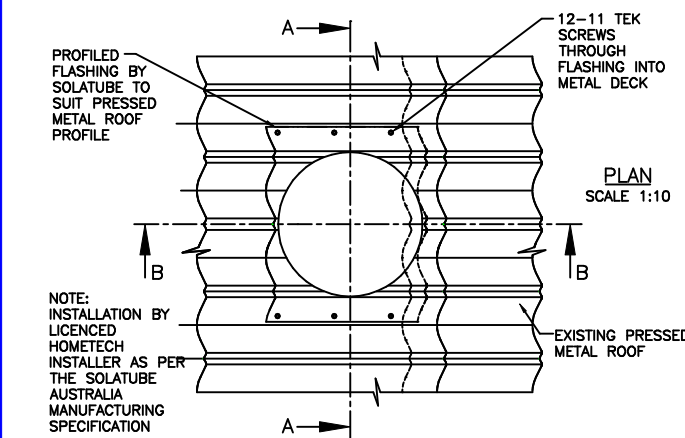

PLAN  
SCALE 1:10

NOTE: INSTALLATION BY LICENCED HOMETECH INSTALLER AS PER THE SOLATUBE AUSTRALIA MANUFACTURING SPECIFICATION

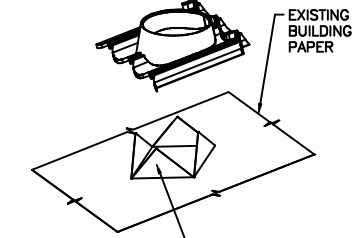

DETAIL D - 3D EXPLODED VIEW  
N.T.S.

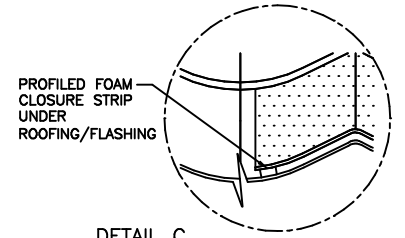

DETAIL C  
N.T.S.

SOLATUBE 290DS DAYLIGHTING SYSTEM WITH SEPERATE MECHANICAL VENTILATION  
INSTALLATION FOR PRESSED METAL ROOF e.g. DECROBOND  
INSTALLATION: INSTALLED BY A LICENCED HOMETECH INSTALLER AS PER THE SOLATUBE AUSTRALIA MANUFACTURING SPECIFICATION

DRAWN	PCR	REVISION	B
DATE	22/10/16	SCALE	1:5, 1:10, NTS
APPROVED	PN	DWG NO.	290DS-VS3004-D
DATE	22/10/16		